



Combinazioni modelli & tessuti / Grid of models & fabrics

 **TIRELLA TESSUTI CONSIGLIATA**
SUGGESTED FABRIC HANGER

Il numero rosso indica lo specifico tessuto sconsigliato all'interno della tirella.
The number of fabric within the fabric hanger shown in red, is not recommended.

 **TIRELLA TESSUTI SCONSIGLIATA**
NOT RECOMMENDED FABRIC HANGER

Il numero verde indica lo specifico tessuto consigliato all'interno della tirella.
The green numbers show the suggested specific fabrics within the fabric hanger.

 **TIRELLE SENZA INDICAZIONI SPECIFICHE**
NO SPECIFIC INSTRUCTIONS

E' necessario prestare attenzione alle indicazioni tecniche e sartoriali riportate sulle stesse.
Please refer to labels shown on the fabric samples.

98 Hip Bazaar **1**
Divina - Divina Melange
Tonus
Hallingdal
Stamskin Top - Extrema
Alcantara
Pelle T / Leather T
Pelle Z / Leather Z
Alcantara

71 Mohair & Velluti / Velvets
73 Grainderiz
81 Uniforms
87 Washables
90 Superwhites
91 FIT
93 Remix **3/5**
94 Timeless
4,8 only cushion
95 Floribunda I **13**
96 Floribunda II
97 Metropolitan
99 Structures
100 Cross Over 1
101 Cross Over 2
102 The Specials
103 My Tip
104 Net - Work

92 Polyrock

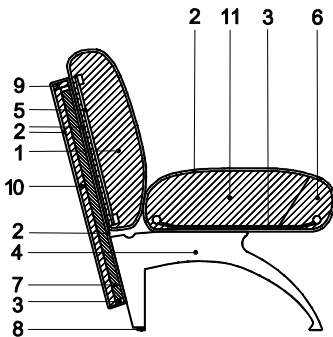

Attenzione Per l'unione degli elementi sono previsti dei dispositivi di fissaggio, senza alcuna maggiorazione, diversi tra di loro, in relazione alla destinazione d'uso.

Attention Elements can be connected without upcharge. Different connectors are supplied for residential or public area use; please specify type on order.

Achtung Fixierungselemente sind ohne Preiszuschlag vorgesehen. Je nach Endbestimmung (Öffentlich od. Privatbereich), werden sie verschieden sind.

Attention Pour unir les éléments entre eux sont prévus des éléments de fixation différents, sans augmentation de prix, par rapport à l'utilisation du Waiting.

Legenda - Description

- 1 6 -9-10-11: Poliuretani a densità e portanza differenziate
- 6 -9-10-11: Polyurethane foam in varied densities
- 6 -9-10-11: Polyurethanschaum in untersch. Raumdichtigkeiten
- 6 -9-10-11: Mousse polyuréth. à densités différenciées
- 2 Ovatta poliestere da 200 gr/mq. Polyester fiberfill 200 gr/mq. Polyesterwatte mit 200 gr/mq. Fibre polyester à 200 gr/mq.
- 3 Struttura in acciaio
Steel frame
Stahlstruktur
Structure en acier
- 4 Piede in alluminio
Aluminum legs
Füß aus Aluminium
Pied aluminium
- 5 Struttura schienale in acciaio
Back frame steel
Stahlstruktur Rückenstütze
Structure du dossier en acier
- 7 Struttura controschienale in acciaio
Back surround frame steel
Stahlstruktur Rückenstütze
Structure du contre dossier en acier
- 8 Piedino per regolazione livello
Height-adjustable glides
Füß regulierbar auf Bodenniveau
Pied pour regulation à niveau

Struttura

Acciaio rivestito con poliuretano espanso ignifugo indeformabile a densità differenziate e fibra poliestere.

Piedi

I piedi sono in pressofusione di alluminio lucidato M3141, regolabili in altezza.

Sovrapprezzi

Nel caso di elementi connessi, il cuscino dello schienale può essere prolungato fino alla fine del controschienale, su un lato o su entrambi.

Il prezzo aggiuntivo, per un solo lato, è di .

Caratteristiche

Il modello WAITING non è sfoderabile.
Si compone di elementi con e senza schienale.

Structure

Stress-resistant flame-retardant polyurethane foam in varied densities and polyester fiberfill on steel frame.

Feet

Polished die-cast aluminum M3141 feet are height-adjustable.

Surcharge

For connected units: with surcharge of (for one side only), back cushion can be produced in the same length as the back surround, on one side or both sides.

Spec. Characteristics

WAITING covers are not removable.
The collection can be delivered with or without back surround.

Struktur

Aus Stahl, mit feuerhemmendem unverformbarem Polyurethanschaum in unterschiedlichen Raumdichtigkeiten und Polyesterwatte.

Füsse

Die Füße sind aus poliertem Aluminium-Druckguss M3141. Sie sind verstellbar.

Aufpreis

Falls die Elemente miteinander verbunden werden, kann der Rückenpolster auf die gleicher Laenge der Rückenstütze gefertigt werden. Bitte angeben ob eine oder beide Seiten.
Aufpreis für eine Seite .

Besonderheiten

Das Modell WAITING ist nicht abziehbar.
Die Kollektion besteht aus Ausführungen.

Structure

En acier recouverte de mousse polyuréthane indéformable ignifugée à densités différenciées et ouatte syntétique.

Pieds

Les pieds sont en pression d'aluminium brillant M3141, réglable en hauteur.

Suppl. de prix

Dans le cas où les éléments sont unis entre eux, le coussin du dossier peut être prolongé à la même longueur que le contredossier, ce la peut être effectué sur un côté ou sur les deux.
Ajoutez SVP pour un côté.

Caractéristiques

Le modèle WAITING n'est pas déhoussable.
Il est prévu des versions avec ou sans dossier.

 **Fodera**
Ersatzbez Cover
Housse

 m **Tessuto**
Stoff Fabric
Tissu

 m² **Pelle**
Leder Leather
Cuir

 Kg **P. lordo**
Bruttogew. Gr. Weight
Poids Brut

 m³ **Volume**
Volumen Volume
Volume

Cod. 04A

Elemento 1p cm.75

1 seater element cm.75
Element 1-Sitzig cm.75
Chaufeuse cm.75

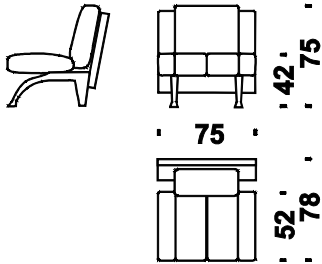

 m 2,7  m² 5,0  Kg 45  m³ 0,60

Cod. 04B

Elemento 1p cm.100

1 seater element cm.100
Element 1-Sitzig cm.100
Chaufeuse cm.100

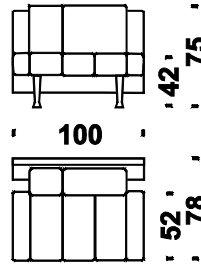

 m 3,5  m² 6,0  Kg 54  m³ 0,90

Cod. 04C

Elemento 1p cm.125

1 seater element cm.125
Element 1-Sitzig cm.125
Chaufeuse cm.125

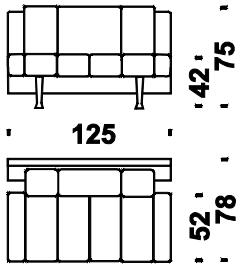

 m 4,4  m² 7,5  Kg 60  m³ 1,20

Cod. 04D

Elemento 2p cm.200

2 seater element cm.200
Element 2-Sitzig cm.200
Canape 2 places cm.200

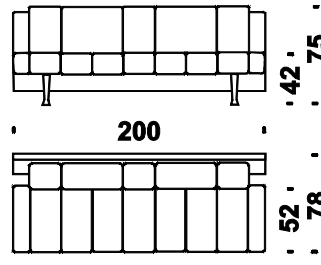

 m 6,4  m² 11,0  Kg 85  m³ 1,50

Cod. 04E

Elemento 3p cm.275

3 seater element cm.275
Element 3-Sitzig cm.275
Canape 3 places cm.275

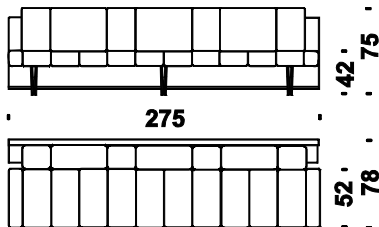

 m 8,7  m² 16,5  Kg 100  m³ 2,40

Cod. 04F

Elem.2p 200 senza schien.

Bench 200 without backrest
Elem.2-Stz.200 ohne Rückenlehne
Banquette 200 sans dos

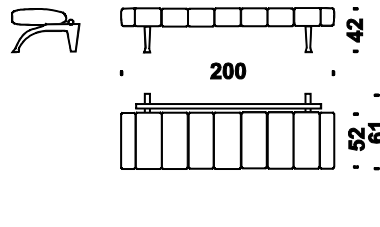

 m 2,7  m² 5,0  Kg 44  m³ 0,75

Fodera
Ersatzbez Cover
Housse

m Tessuto
Stoff Fabric
Tissu

m² Pelle
Leder Leather
Cuir

Kg P. lordo
Bruttogew. Gr. Weight
Poids Brut

m³ Volume
Volumen Volume
Volume

Cod. 04G

Elem.3p 275 senza schien.

Bench 275 without backrest
Elem.3-Stz.275 ohne Rückenlehne
Banquette 275 sans dos

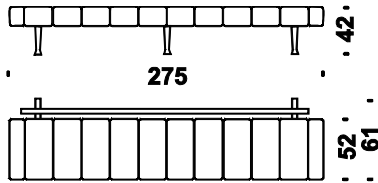

m 3,5 m² 6,5 Kg 50 m³ 1,30

Cod. 0P9

Panca doppia da cm.125

Double face bench-cm.125
Double face Bank-cm.125
Banquette double face-cm.125

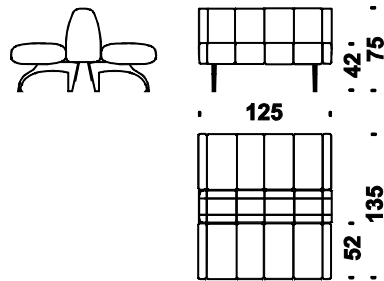

m 6,0 m² 11,0 Kg 80 m³ 1,70

Cod. 0T3

Panca doppia da cm.200

Double face bench-cm.200
Double face Bank-cm.200
Banquette double face-cm.200

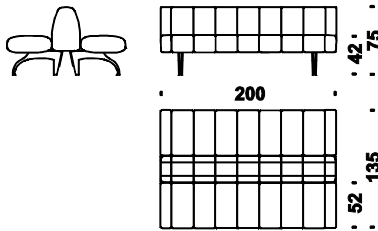

m 9,9 m² 18,8 Kg 110 m³ 2,60

Cod. 0U1

Panca doppia da cm.275

Double face bench-cm.275
Double face Bank-cm.275
Banquette double face-cm.275

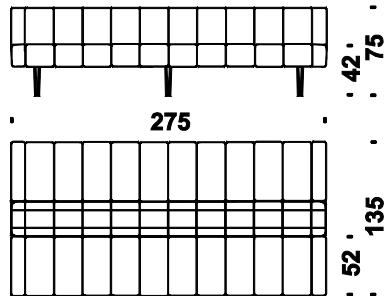

m 12,2 m² 23,2 Kg 130 m³ 3,80

Cod. 0S9

Elemento semicerchio

Half circle element
Halb Kreis Element
Elément demi-cercle

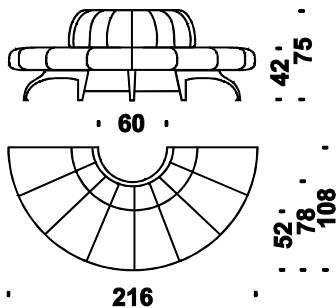

m 7,5 m² 14,0 Kg 85 m³ 2,00

Cod. 04H

Angolo chiuso

Closed corner
Geschlossene Ecke
Angle fermé

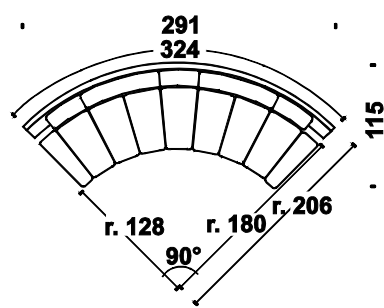

m 10,5 m² 19,8 Kg 90 m³ 2,90

 **Fodera** Cover
Ersatzbez Housse

 m **Tessuto** Fabric
Stoff Tissu

 m² **Pelle** Leather
Leder Cuir

 Kg **P. lordo** Gr. Weight
Bruttogew. Poids Brut

 m³ **Volume** Volume
Volumen Volume

Cod. 04I

Angolo aperto

Open corner
Offene Ecke
Angle ouvert

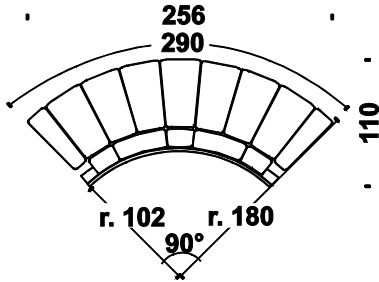

 m 7,3  m² 13,2  Kg 90  m³ 2,20

Cod. 04L

Angolo chiuso s/schienale

Closed corner without backrest
Geschlossene Ecke ohne Rück.
Angle fermé sans dos

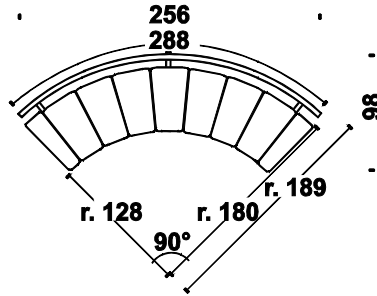

 m 3,3  m² 7,2  Kg 50  m³ 1,20

Cod. 04M

Angolo aperto s/schienale

Open corner without backrest
Offene Ecke ohne Rückenlehne
Angle ouvert sans dos

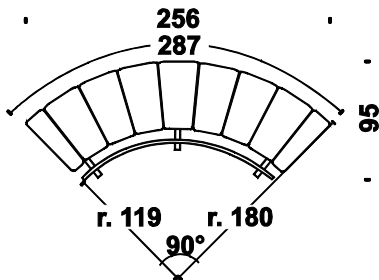

 m 3,3  m² 7,1  Kg 50  m³ 1,20