



## Combinazioni modelli & tessuti / Grid of models & fabrics

### 😊 TIRELLA TESSUTI CONSIGLIATA SUGGESTED FABRIC HANGER

Il numero rosso indica lo specifico tessuto sconsigliato all'interno della tirella.  
The number of fabric within the fabric hanger shown in red, is not recommended.

90 Superwhites  
92 Polyrock  
95 Floribunda I  
96 Floribunda II  
97 Metropolitan  
98 Hip Bazaar  
100 Cross Over 1  
101 Cross Over 2  
103 My Tip  
104 Net - Work  
105 Chelsea - Girl  
Divina - Divina Melange  
Tonus  
Pelle T / Leather T

### 😞 TIRELLA TESSUTI SCONSIGLIATA NOT RECOMMENDED FABRIC HANGER

Il numero verde indica lo specifico tessuto consigliato all'interno della tirella.  
The green numbers show the suggested specific fabrics within the fabric hanger.

73 Grainderiz  
81 Uniforms  
87 Washables  
91 FIT 2  
93 Remix 1/3  
99 Structures **bergen wave**  
102 The Specials  
Stamskin Top - Extrema

### 😊 TIRELLE SENZA INDICAZIONI SPECIFICHE NO SPECIFIC INSTRUCTIONS

E' necessario prestare attenzione alle indicazioni tecniche e sartoriali riportate sulle stesse.  
Please refer to labels shown on the fabric samples.

71 Mohair & Velluti / Velvets  
94 Timeless  
4,8 only cushion  
Hallingdal  
Alcantara  
Pelle Z / Leather Z

Per qualsiasi richiesta particolare non prevista, si prega di contattare il Ns Ufficio commerciale.  
For specific questions or requests, please contact your sales rep. or our sales office in Italy.

## Materiale e finiture / Materials and Finishings / Materialien und Ausführungen / Materiaux et Finitions

Colori tavoli Springfield 2008 / Springfield 2008 Tables colors / Farben Tische Springfield 2008 / Couleurs Tables Springfield 2008



Ral 9003  
Bianco lucido  
White polished  
Weiss hochglanz  
Blanc brillant



Ral 9005  
Nero lucido  
Black polished  
Schwarz hochglanz  
Noir brillant



Ral 3020  
Rosso lucido  
Red polished  
Rot hochglanz  
Rouge brillant

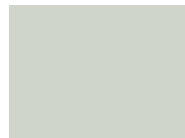

Ral 7047  
Grigio lucido  
Grey polished  
Grau hochglanz  
Gris brillant

Le finiture qui riprodotte sono indicative. Leggeri scostamenti non verranno accettati come reclamo.  
Finishings may slightly change. Light differences will not be accepted as complaint.  
Farbabweichungen gegenüber den Mustern sind möglich und müssen akzeptiert werden.  
Les couleurs reprises sur cette page sont indicatives et de légères différences ne seront pas acceptées comme non-conformités.

**Attenzione** Per ordini di composizioni, allegare un'accurata descrizione integrata con un disegno. Nelle comp. realizzabili con gli elementi riportati, considerare una luce di 3,5 cm. tra gli elementi stessi. Le dimensioni d'ingombro riportate sui disegni, si intendono non comprensive dei dispositivi di collegamento. Nel caso di ordini di elementi per comp. a sé stanti o con tavolo inserito, si prega di specificarlo all'atto dell'ordinazione per permettere una corretta produzione della fodera.

**Attention** When ordering compositions, please include an accurate description and plan of configuration. When creating compositions, please note that the linking device adds 3,5 cm / 1 3/8" to width of single elements. If one element is to be used alone or with a table, please indicate it on your order to allow us to produce the cover correctly.

**Achtung** Fuer Auftraegen fuer Sitzlandsch. bitte eine genaue Beschreibung beilegen, mit Zeichnung. Bei Zusammen. von Einzel. bitte beruecksicht., dass die Verbindungstuecke 3,5 cm. lang sind. Die Zeichnungen in der Preisliste sind ohne dieses Mass. Dieser Abstand muss dann auch fuer die Gesamtbreite der Zusammen. beruecksichtigt werden. Bitte mitteilen ob Einzel. freistehend oder in Verbindung mit Tische bestellt werden damit die Bezuege korrekt gefertigt werden.

**Attention** Pour le commandes de comp., envoyez une description précise et un dessin. Pour le comp. réalisées avec des éléments composites, considérez un espace de 3,5 cm. entre les éléments. Les dimensions reportées sur les dessins ne tiennent pas compte de ces espaces entre les éléments. Dans le cas ou les éléments d'une comp. sont utilisées seuls ou avec une table, veuillez nous en aviser dans votre commande pour nous permettre une finition correcte de la housse.

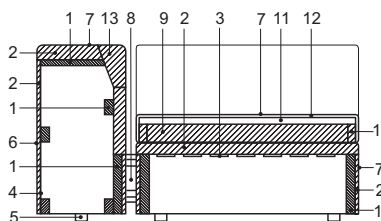

## Legenda - Description

- 1 Struttura in legno  
Hardwood frame  
Holzstruktur  
Structure en bois
- 2 9 - 10 - 13: Poliuretani a densità e portanza differenziate  
9 - 10 - 13: Polyurethane foam in varied densities  
9 - 10 - 13: Polyurethanschaum in untersch. Raumdichtigkeiten  
9 - 10 - 13: Mousse polyuréth. à densités différenciées
- 3 Cinghie elastiche da 60 mm.  
Elastic belts 60 mm.  
Elastische Gurte 60 mm.  
Sangles élastiques de 60 mm.
- 4 Legno con spessore 2,5 mm.  
Wood 2,5 mm thick  
Holz Stärke 2,5 mm.  
Bois de 2,5 mm. d'épaisseur
- 5 Piedi in polipropilene  
Polypropylene feet  
Polypropylenfuss  
Pieds en polypropylène
- 6 Ovatta poliestere da 100 gr/mq.  
Polyester fiberfill 100 gr/mq.  
Polyesterwatte 100 gr/mq.  
Fibre Polyestère à 100 gr/mq.
- 7 Rivestimento in tela di cotone 100%  
100% cotton cover  
Überzug aus Baumwolle 100%  
Revêtement coton 100%
- 8 Dispositivo di colleg. in acciaio  
Steel joining device  
Verbindungseinheit in Stahl  
Dispositif d'union en acier
- 11 Settori con piumino d'oca  
Goose down insert  
Einlagen mit Gans Daune  
Sections à duvet d'oie
- 12 Tela cotone 100% accoppiata ad ovatta poliestere da 100 gr/mq.  
100% cotton fabric with polyester fiberfill 100 gr/mq.  
Baumwollstoff verbunden mit Polyesterwatte 100 gr/mq.  
Mélange de coton 100% et de fibre polyestère à 100 gr/mq.

## Struttura

Fusto in legno rivestito con poliuretano espanso indeformabile a densità differenziate e fibra poliestere. Piedi in polipropilene. La poltroncina (cod. 061) ha i piedi in alluminio spazzolato. Il colore dei copri dispositivo di collegamento è NERO. TAVOLI: Piano in alluminio alveolare verniciato bianco RAL 9003, nero RAL 9005, rosso RAL 3020 e grigio RAL 7047.

## Imbottitura cuscini

I cuscini del sedile sono in piumino d'oca con supporto in poliuretano espanso a densità differenziate e fibra poliestere. I cuscini dello schienale sono in piuma d'oca.

## Sovrapprezzi

I prezzi indicati a listino sono del solo elemento. Il prezzo totale dell'articolo si ottiene aggiungendo al prezzo dell'elemento quello dei cuscini di schiena nelle quantità desiderate dal cliente. I cuscini tratteggiati indicano le quantità suggerite dall'azienda.

## Caratteristiche

La collezione SPRINGFIELD 2008 è sfoderabile e SMONTABILE ad eccezione dei codici: 001-011-04R-072-073-012-013.

NON SI ACCETTANO ORDINI DI ELEMENTI FUORI MISURA.

## Structure

Stress-resistant polyurethane foam in varied densities and polyester fiberfill on hardwood frame. Polypropylene feet. Small armchair (cod. 061) has aluminum feet. Joining device cover is BLACK. TABLES: Lacquered top is honeycomb aluminum. Available colors: white RAL 9003, black RAL 9005, red RAL 3020 or grey RAL 7047.

## Padding

Seat cushions are goose down over polyurethane foam in varied densities and polyester fiberfill. Back cushion are goose dawn.

## Surcharge

Sofa prices do not include loose back cushions; add prices of loose back cushions for total price. Loose back cushions as shown in the drawings are only a suggestion of how many may be used.

## Spec. Characteristics

SPRINGFIELD 2008 fabric covers are completely removable. Elements are delivered unassembled, except for codes: 001-011-04R-072-073-012-013.

REQUESTS FOR SPECIAL SIZES CANNOT BE ACCEPTED.

## Struktur

Aus Holz, mit unverformbarem Polyurethanschaum in unterschiedlichen Raumdichtigkeiten und Polyesterwatte. Füße: polypropylen. Die Fuesse der Sessel klein (Kod. 061) sind aus Aluminium. Die Farbe für die Verbindungselemente ist SCHWARZ. TISCHEN: Lackierte Tischplatte aus "Honeycomb" Aluminium. Farben: weiss RAL 9003, schwarz RAL 9005, rot RAL 3020 und grau RAL 7047.

## Kissen Füllung

Die Sitzkissen sind aus Gaensedaune mit Polyurethanschaum kern in unterschiedlicher Raumdichtigkeit und Polyesterwatte. Die Rückenkissen ausschliesslich in Daune.

## Aufpreis

Angegebene Preise beziehen sich ausschliesslich auf die Polsterelemente. Lose Kissen sind im Preis nicht einbegriffen. Bitte Preis der losen Kissen dazurechnen um den Totalpreis zu erhalten.

## Besonderheiten

Kollektion SPRINGFIELD 2008 ist Komplett abziehbar und sind MONTIERBAR, ausgenommen der Kodens: 001-011-04R-072-073-012-013.

SONDERANFERTIGUNG N KOENNEN NICHT ANGENOMMEN WERDEN.

## Structure

En bois recouverte de mousse polyuréthane indéformable à densités différenciées et ouatte syntétique. Pieds en polypropylène. La petit fauteuil (cod. 061) a les pieds en aluminium. Le couleur du dispositif d'union est NOIR. TABLES: Plateau en aluminium "Honeycomb" verni blanc RAL 9003, noir RAL 9005, rouge RAL 3020 et gris RAL 7047.

## Rembourrage

Les coussins de l'assise sont en duvet d'oie avec support en polyuréthane expansé à densités différenciées et ouatte synthétique. Les coussins du dossier sont en duvet.

## Suppl. de prix

Les prix indiqués se réfèrent seulement à l'élément. Le prix final s'obtient en y ajoutant le prix des coussins du dossier. Le client peut commander la quantité désirée. Le nombre de coussins dossier indiqué en pointilles est indicatif et seulement conseille par Moroso.

## Caractéristiques

La collection SPRINGFIELD 2008 est complètement déhoussable et est DEMONTABLE à l'exception des codes: 001-011-04R-072-073-012-013.

COMMANDES HORS MESURE NE SONT PAS ACCEPTÉES.

Fodera Cover Tessuto m Fabric Pelle m<sup>2</sup> Leather P. lordo Kg Bruttogew. Gr. Weight Poids Brut Volume m<sup>3</sup> Volumen Volume

## Cod. 002

### Divano 2 posti

2 seater sofa  
Sofa 2-Sitzig  
Canapé 2 places

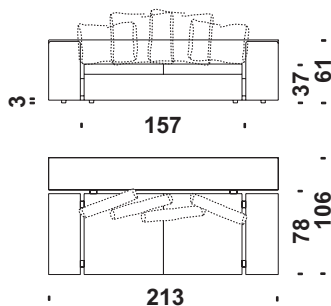

m 10,3 m<sup>2</sup> 19,0 Kg 106 m<sup>3</sup> 1,40

## Cod. 018

### Divano 2 posti major

2 seater sofa major  
Sofa 2-Sitzig major  
Canapé 2 places major

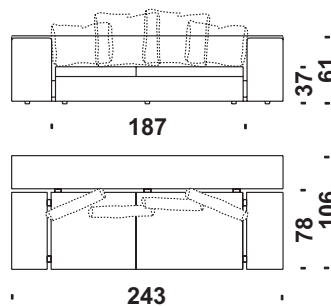

m 11,3 m<sup>2</sup> 21,0 Kg 113 m<sup>3</sup> 1,60

## Cod. 003

### Divano 3 posti

3 seater sofa  
Sofa 3-Sitzig  
Canapé 3 places

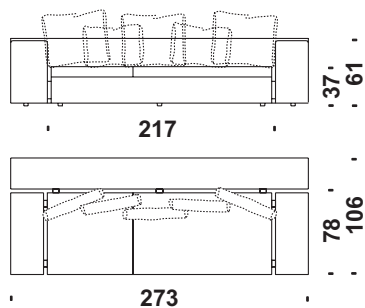

m 12,0 m<sup>2</sup> 22,8 Kg 122 m<sup>3</sup> 2,50

## Cod. FL0EU

### Field cuscino schiena 60x54x7

Field back cushion 60x54x7  
Field Ruecken Kissen 60x54x7  
Field coussin dos 60x54x7

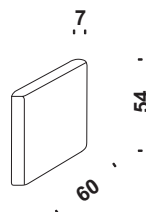

m 1,0 m<sup>2</sup> 1,3

## Cod. FL0EX

### Field cuscino sch.con rullo 60x54x7

Field back cush.with roll 60x54x7  
Field Ruecken Kiss.mit rolle 60x54x7  
Field couss.dos avec rouleau 60x54x7

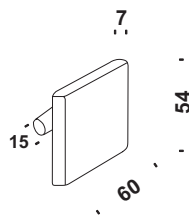

m 1,7 m<sup>2</sup> 2,1

## Cod. FL0KL

### Field cuscino schiena 56x43x9

Field back cushion 56x43x9  
Field Ruecken Kissen 56x43x9  
Field coussin dos 56x43x9

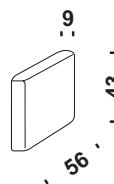

m 1,2 m<sup>2</sup> 1,5

 **Fodera**  
Ersatzbez Cover  
Housse

 m **Tessuto**  
Stoff Fabric  
Tissu

 m<sup>2</sup> **Pelle**  
Leder Leather  
Cuir

 Kg **P. lordo**  
Bruttogew. Gr. Weight  
Poids Brut

 m<sup>3</sup> **Volume**  
Volumen Volume  
Volume

## Cod. 001

### Poltrona 75

Armchair 75  
Sessel 75  
Fauteuil 75

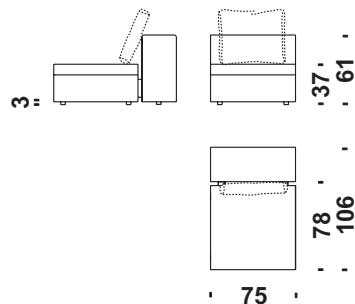

 m 4,0  m<sup>2</sup> 8,3  Kg 45  m<sup>3</sup> 0,60

## Cod. 01G

### Poltrona con braccioli

Armchair with arms  
Sessel mit Armlehnen  
Fauteuil avec accoudoirs

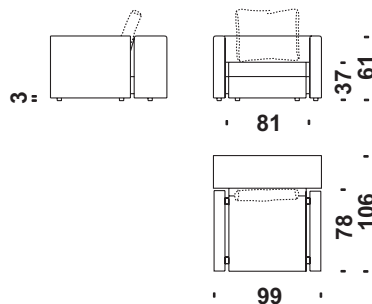

 m 6,6  m<sup>2</sup> 12,6  Kg 52  m<sup>3</sup> 1,00

## Cod. 011

### Elemento centrale 75

Central element 75  
Zentralelement 75  
Elément central 75

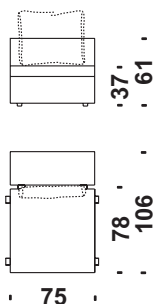

 m 4,0  m<sup>2</sup> 8,4  Kg 45  m<sup>3</sup> 0,60

## Cod. 04R

### Elemento centrale 105

Central element 105  
Zentralelement 105  
Elément central 105

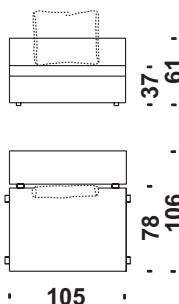

 m 4,8  m<sup>2</sup> 9,1  Kg 49  m<sup>3</sup> 0,70

## Cod. 04T

### Elemento centrale 180

Central element 180  
Zentralelement 180  
Elément central 180

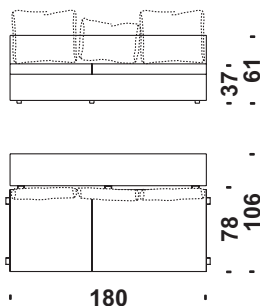

 m 7,3  m<sup>2</sup> 14,4  Kg 78  m<sup>3</sup> 1,20

## Cod. 04S

### Chaise Longue centrale

Chaise Longue central  
Chaise Longue Zentral  
Chaise Longue central

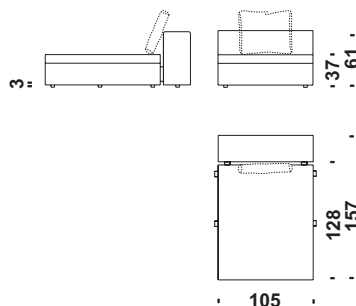

 m 5,4  m<sup>2</sup> 11,2  Kg 57  m<sup>3</sup> 1,20

 **Fodera**  
Ersatzbez Cover  
Housse

 m **Tessuto**  
Stoff Fabric  
Tissu

 m<sup>2</sup> **Pelle**  
Leder Leather  
Cuir

 Kg **P. lordo**  
Bruttogew. Gr. Weight  
Poids Brut

 m<sup>3</sup> **Volume**  
Volumen Volume  
Volume

## Cod. 073

### Angolo sinistro

Corner left  
Ecke links  
Angle gauche

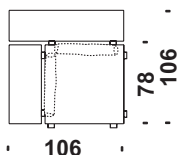
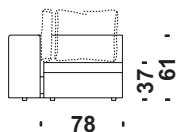

 m 5,3  m<sup>2</sup> 10,1  Kg 54  m<sup>3</sup> 0,70

## Cod. 072

### Angolo destro

Corner right  
Ecke rechts  
Angle droit

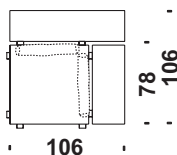
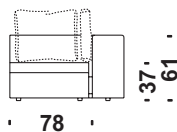

 m 5,3  m<sup>2</sup> 10,1  Kg 54  m<sup>3</sup> 0,70

## Cod. 013

### Elemento 1p sinistro

Lateral 1 seat unit left  
Seiten Element links  
Élément latérale gauche

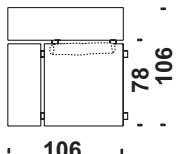
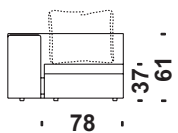

 m 5,7  m<sup>2</sup> 10,9  Kg 55  m<sup>3</sup> 0,70

## Cod. 012

### Elemento 1p destro

Lateral 1 seat unit right  
Seiten Element rechts  
Élément latérale droit

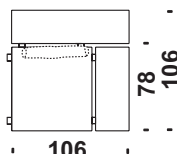
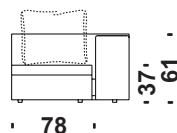

 m 5,7  m<sup>2</sup> 10,9  Kg 55  m<sup>3</sup> 0,70

## Cod. 023

### Elemento 2p sinistro

Lateral 2 seat unit left  
2 Sitz-Element links  
Élément latérale gauche

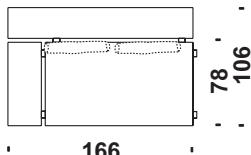
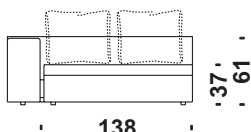

 m 7,7  m<sup>2</sup> 14,2  Kg 78  m<sup>3</sup> 1,20

## Cod. 022

### Elemento 2p destro

Lateral 2 seat unit right  
2 Sitz-Element rechts  
Élément latérale droit

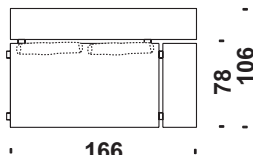
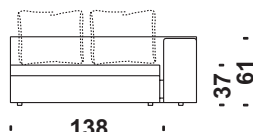

 m 7,7  m<sup>2</sup> 14,2  Kg 78  m<sup>3</sup> 1,20

Fodera Cover Tessuto m Fabric Pelle m<sup>2</sup> Leather P. lordo Kg Gr. Weight Volume m<sup>3</sup> Volume Volume

Ersatzbez Housse Stoff Tissu Leder Bruttogew. Poids Brut Volumen Volume

## Cod. 037 **Elemento 2p major sinistro**

Lateral 2 seat unit major left  
2-Sitz Element major links  
Elément latérale major gauche

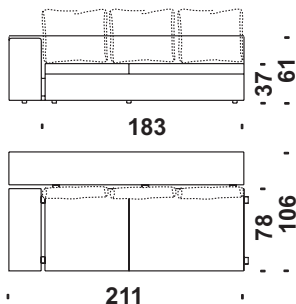

m 9,7 m<sup>2</sup> 17,6 Kg 96 m<sup>3</sup> 1,60

## Cod. 031 **Elemento 2p major destro**

Lateral 2 seat unit major right  
2-Sitz Element major rechts  
Elément latérale major droit

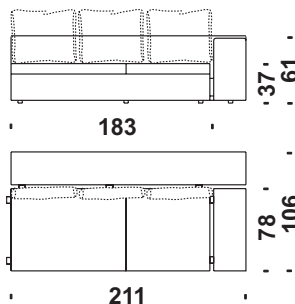

m 9,7 m<sup>2</sup> 17,6 Kg 96 m<sup>3</sup> 1,60

## Cod. 033 **Elemento 3p sinistro**

Lateral 3 seat unit left  
3-Sitz Element links  
Elément latérale gauche

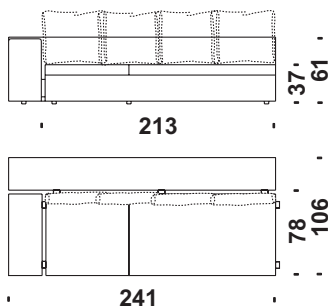

m 10,7 m<sup>2</sup> 19,7 Kg 103 m<sup>3</sup> 1,80

## Cod. 032 **Elemento 3p destro**

Lateral 3 seat unit right  
3-Sitz Element rechts  
Elément latérale droit

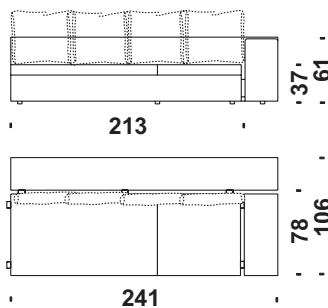

m 10,7 m<sup>2</sup> 19,7 Kg 103 m<sup>3</sup> 1,80

## Cod. 06W **Chaise Longue term.sx**

Chaise Longue side left  
Chaise Longue Seitl.links  
Chaise Longue à côté gauche

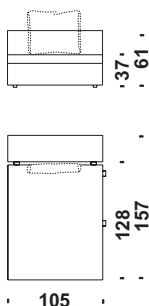

m 5,4 m<sup>2</sup> 11,2 Kg 57 m<sup>3</sup> 1,20

## Cod. 06V **Chaise Longue term.dx**

Chaise Longue side right  
Chaise Longue Seitl.rechts  
Chaise Longue à côté droit

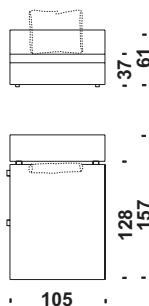

m 5,4 m<sup>2</sup> 11,2 Kg 57 m<sup>3</sup> 1,20

 **Fodera** Cover  
 Ersatzbez Housse  
 m **Tessuto** Fabric  
 Stoff Tissu  
 m<sup>2</sup> **Pelle** Leather  
 Leder Cuir  
 Kg **P. lordo** Bruttogew.  
 Gr. Weight Poids Brut  
 m<sup>3</sup> **Volume** Volume  
 Volumen Volume

## Cod. 0D4

### Chaise Longue bracc.sx

Chaise Longue arm left  
 Chaise Longue Armlehne links  
 Chaise Longue accoudoir gauche

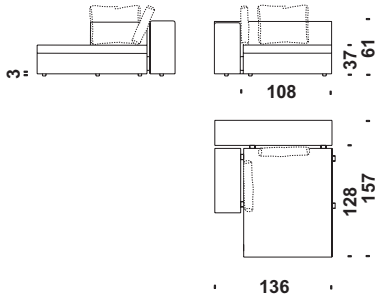

 m 7,3  
 m<sup>2</sup> 15,3  
 Kg 79  
 m<sup>3</sup> 1,40

## Cod. 0D3

### Chaise Longue bracc.dx

Chaise Longue arm right  
 Chaise Longue Armlehne rechts  
 Chaise Longue accoudoir droit

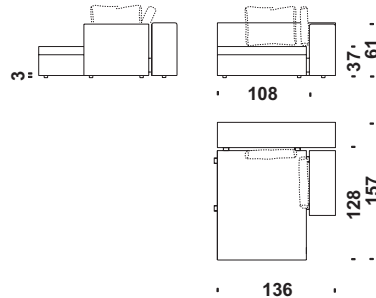

 m 7,3  
 m<sup>2</sup> 15,3  
 Kg 79  
 m<sup>3</sup> 1,40

## Cod. 061

### Poltroncina

Small armchair  
 Sessel Klein  
 Petit fauteuil

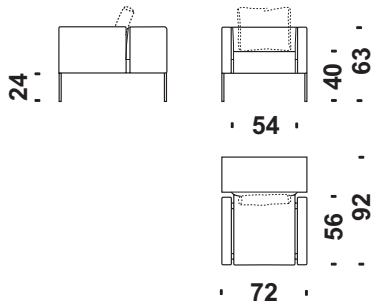

 m 3,3  
 m<sup>2</sup> 5,6  
 Kg 28  
 m<sup>3</sup> 0,60

## Cod. 0G1

### Pouf centrale 75x106

Central stool 75x106  
 Zentral Hocker 75x106  
 Pouf central 75x106

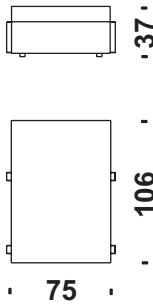

 m 3,1  
 m<sup>2</sup> 6,5  
 Kg 34  
 m<sup>3</sup> 0,40

## Cod. 0G4

### Pouf Lounge 106x75

Stool Lounge 106x75  
 Hocker Lounge 106x75  
 Pouf Lounge 106x75

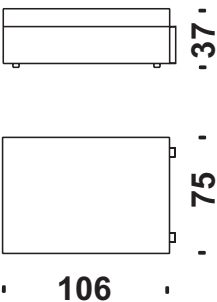

 m 3,1  
 m<sup>2</sup> 6,5  
 Kg 34  
 m<sup>3</sup> 0,40

## Cod. 0G2

### Pouf terminale sx 75x106

Terminal stool left 75x106  
 Abschlusshocker links 75x106  
 Pouf terminal gauche 75x106

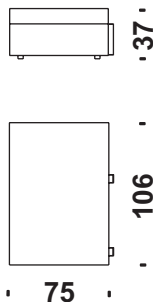

 m 3,1  
 m<sup>2</sup> 6,4  
 Kg 34  
 m<sup>3</sup> 0,40

 **Fodera**  
Ersatzbez Cover  
Housse

 m **Tessuto**  
Stoff Fabric  
Tissu

 m<sup>2</sup> **Pelle**  
Leder Leather  
Cuir

 Kg **P. lordo**  
Bruttogew. Gr. Weight  
Poids Brut

 m<sup>3</sup> **Volume**  
Volumen Volume  
Volume

## Cod. 0G3

### Pouf terminale dx 75x106

Terminal stool right 75x106  
Abschlusshocker rechts 75x106  
Pouf terminal droit 75x106

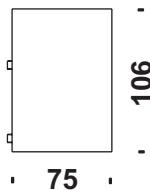
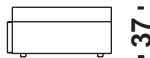

 m 3,1  m<sup>2</sup> 6,5  Kg 34  m<sup>3</sup> 0,40

## Cod. 0G5

### Pouf centrale 106x106

Central stool 106x106  
Zentral Hocker 106x106  
Pouf central 106x106

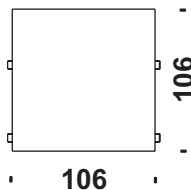
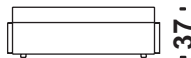

 m 4,2  m<sup>2</sup> 8,1  Kg 40  m<sup>3</sup> 0,50

## Cod. 0G8

### Pouf ad angolo 106x106

Corner stool 106x106  
Eckenhocker 106x106  
Pouf angle 106x106

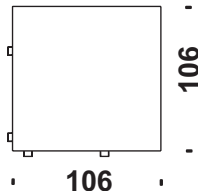
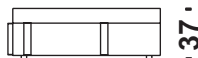

 m 4,2  m<sup>2</sup> 8,1  Kg 40  m<sup>3</sup> 0,50

## Cod. 0G6

### Pouf terminale sx 106x106

Terminal stool left 106x106  
Abschlusshocker links 106x106  
Pouf terminal gauche 106x106

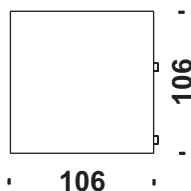

 m 4,2  m<sup>2</sup> 8,1  Kg 40  m<sup>3</sup> 0,50

## Cod. 0G7

### Pouf terminale dx 106x106

Terminal stool right 106x106  
Abschlusshocker rechts 106x106  
Pouf terminal droit 106x106

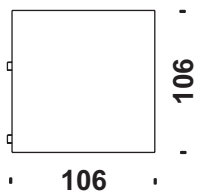
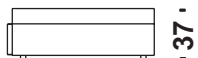

 m 4,2  m<sup>2</sup> 8,1  Kg 40  m<sup>3</sup> 0,50

## Cod. 017

### Springfield 2008 pouf 75x106

Springfield 2008 stool 75x106  
Springfield 2008 Hocker 75x106  
Springfield 2008 pouf 75x106

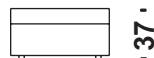

 m 3,1  m<sup>2</sup> 6,4  Kg 34  m<sup>3</sup> 0,40

 **Fodera**  
Ersatzbez Cover  
Housse

 m **Tessuto**  
Stoff Fabric  
Tissu

 m<sup>2</sup> **Pelle**  
Leder Leather  
Cuir

 Kg **P. lordo**  
Bruttogew. Gr. Weight  
Poids Brut

 m<sup>3</sup> **Volume**  
Volumen Volume  
Volume

## Cod. 077

### Springfield 2008 pouf 106X106

Springfield 2008 stool 106X106  
Springfield 2008 Hocker 106X106  
Springfield 2008 pouf 106X106

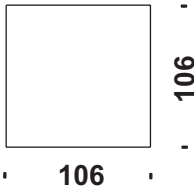
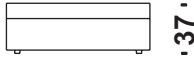

106

 m 4,2

 m<sup>2</sup> 8,1

 Kg 40

 m<sup>3</sup> 0,50

## Cod. SL0CC

### Tavolo 98x98x28

Table 98x98x28  
Tisch 98x98x28  
Table 98x98x28

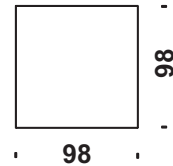

98

 Kg 15

 m<sup>3</sup> 0,35

## Cod. SL0CG

### Tavolo 98x49x28

Table 98x49x28  
Tisch 98x49x28  
Table 98x49x28

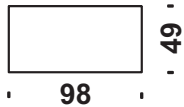
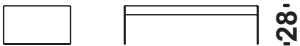

98

49

 Kg 8

 m<sup>3</sup> 0,30

## Cod. SL0CH

### Tavolo 147x49x28

Table 147x49x28  
Tisch 147x49x28  
Table 147x49x28

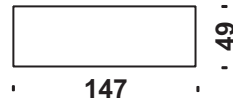
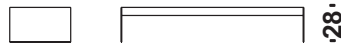

147

49

 Kg 11

 m<sup>3</sup> 0,30